

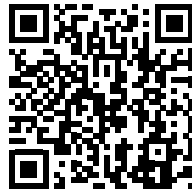

CINEMATELIER™ COLLECTION

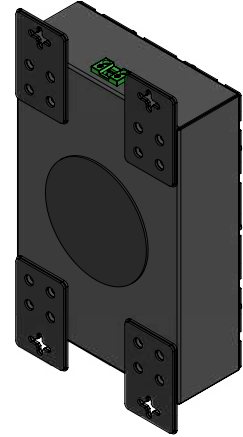
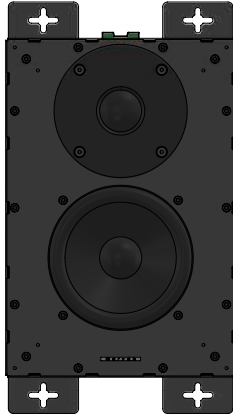

**SCAN OR CLICK TO EXTEND  
YOUR GARVAN WARRANTY FOR FREE!**

3 years included, with the option to add  
2 extra years at no additional cost.

## OVERVIEW DESCRIPTION – UNIQUE DESCRIPTION PRODUCT

The Garvan KA213H is a versatile 2-way loudspeaker from the CinemAtelier™ Collection, engineered for on-wall and on-ceiling installation in high-end audio and cinema environments. With its closed-box design and black lacquered metal cabinet, it ensures both durability and discreet integration into modern interiors. Featuring a 130 mm woofer and a 25 mm tweeter, the KA213H delivers precise, balanced sound reproduction with wide dispersion, making it ideal for immersive home cinema, conference rooms, and multi-purpose spaces that require refined audio performance without compromising design.

## KEY FEATURES

2-way loudspeaker with 130 mm woofer + 25 mm tweeter

Power handling: 80 W AES / 160 W continuous

Sensitivity: 88 dB (2.83V/1m)

Maximum SPL: 119 dB @ 1 m

Frequency response: 80 Hz – 20 kHz (–3 dB) with preset EQ

Wide coverage: >120° (1–4 kHz) for consistent sound dispersion

Closed-box design: compact, elegant, and resonance-controlled

Cabinet: black lacquered metal for strength and minimalistic aesthetics

Installation flexibility: suitable for concrete, plasterboard, wooden, or modular panel surfaces

Indoor use with Phoenix connectors supporting 18 AWG to 11 AWG cables

Lightweight: 2.63 kg for easy mounting

Extended warranty: 3+1+1 years with free registration

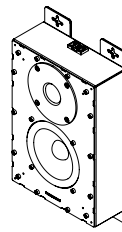

<b>NAME INSTALLATION</b>	<b>CinemaAtelier</b>
Type Installation	On-Wall / On-Ceiling Speaker, closed box
Surface Compatibility	Suitable for installation in, concrete wall, Plasterboard, wooden panels, modular panel, and similar.
Installation Requirements:	Support thickness suitable for product weight
<b>SINGLE LOUDSPEAKER PERFORMANCE</b>	
AES Power Handling	80 W
Continuous Power Handling ***	160 W
Sensitivity 2,83V / 1m ****	88 dB
Sensitivity 1W/1m ****	88dB
Calculated Maximum SPL @ 1m*	119 dB
<b>TRANSDUCER</b>	
Type	2 Way
Nominal size	WF 130 mm + TW 25mm
Nominal Impedance	8Ω
Loudspeaker EQ	Not required, Garvan Preset EQ, Filter and protection available
Recommended High-Pass Filter Protection	55 Hz with 48 dB/Oct. High pass Filter
Frequency Response (-3 dB)	80 Hz - 20 kHz **
Frequency Range (-10 dB)	58 Hz - 20 kHz **
Nominal Coverage Angle (1 KHz - 4 kHz)	> 120°
Nominal Coverage (1 KHz – 10 kHz)	120
<b>PHYSICAL</b>	
Frame Material	Black lacquered metal cabinet
Speaker support Material	Black laquared metal support
Cover	NC
<b>ENVIRONMENTAL FEATURES</b>	
Environment of Use	Indoor environments
Operating Temperature Range *****	
environmental protection.	
Connectors	Phoenix connector. Accepts 18 AWG (0.8 mm <sup>2</sup> ) to 11 AWG (4,17 mm <sup>2</sup> ) size wire.
Maximum Ceiling Thickness	
Product Dimensions	
Ceiling Cutout	
Net Weight, Frame	
Net Weight, Loudspeaker	
Net Weight, Cover	

LOGISTICAL DATA			
Packaging dimensions			
Shipping Weight			
Quantity of products per package	1 to 2 based on logistics optimization per shipment		
MAINTENANCE			
Cleaning Method	microfiber cloth		
General precautions	do not use harsh cleaning products		
INCLUDED ACCESSORIES			
OPTIONAL ACCESSORIES			
Transformer for high line voltage	TRT052 – 70/100V - 25/37/50W		
Transformer for high line voltage	TRT054 – 70/100V - 10/15/20W		
Cover installation kit	GAR136		
<b>Cable size/load</b>	<b>8 ohm</b>	<b>4 ohm</b>	<b>2 ohm</b>
2 sq mm.	20m / 65ft.	10m / 32ft	5m / 16ft
2,5 sq mm.	30m / 100ft.	15m / 50ft	7,5m / 25ft
4 sq mm.	60m / 200ft.	30m / 100ft	15m / 50ft

#### NOTES:

\* Maximum SPL calculated from sensitivity and power handling specifications, using a signal with crest factor 4 (12dB), exclusive of power compression.

\*\* With dedicated preset

\*\*\* Power on Continuous Program is defined as 3 dB greater than the Nominal rating.

\*\*\*\* average SPL measured from 200 Hz to 1,5 kHz

\*\*\*\*\* With dedicated ignition and maintenance process

### CINEMA CODES

1 Loudspeaker **KA213H**

AES POWER **80 W**  
 TYPE **2 WAY**  
 NOM. SIZE **WF 130 mm + TW 25 mm**  
 NOM. IMP. **8Ω**

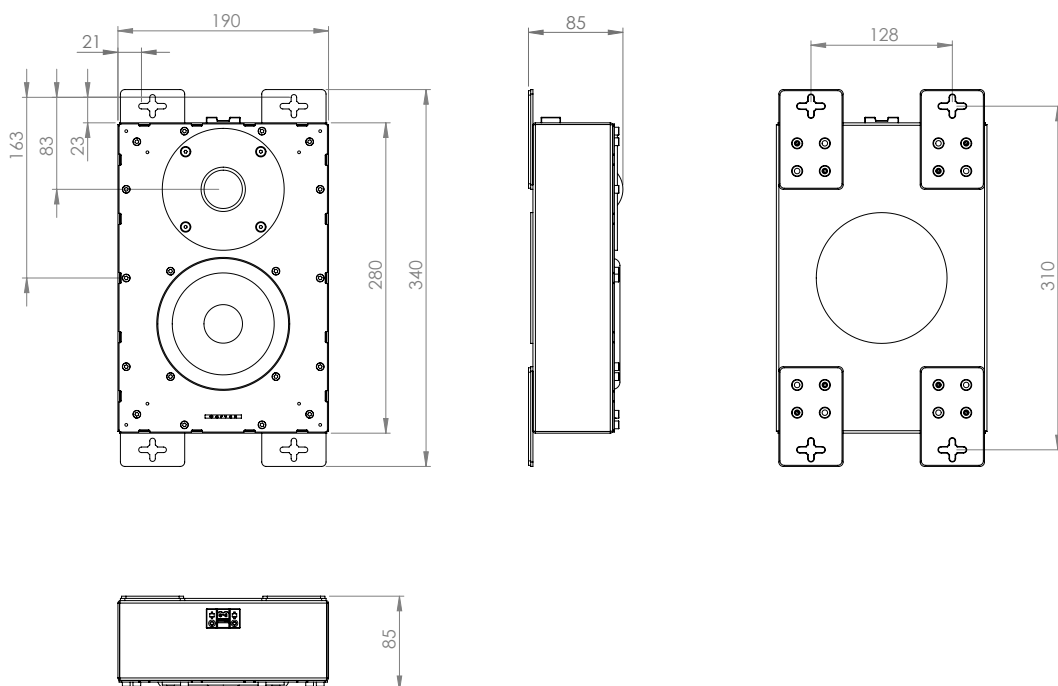
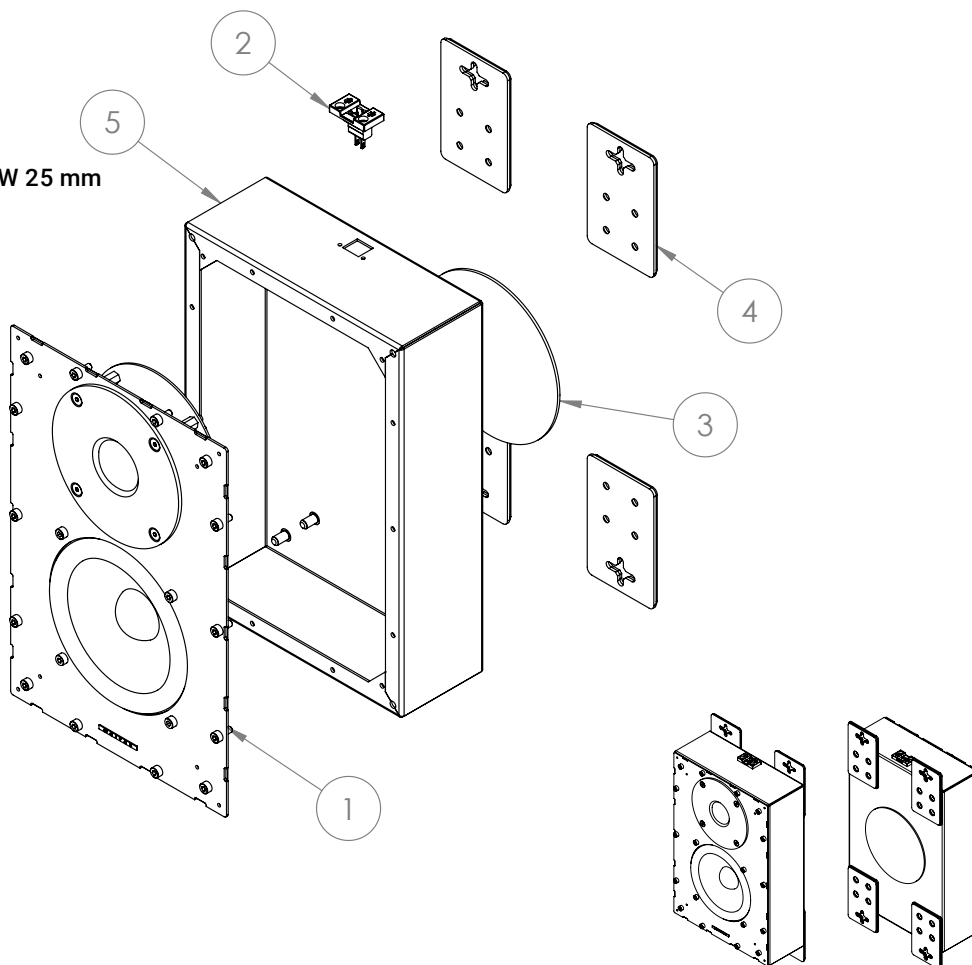

# INSTALLATION INSTRUCTIONS **KA213H Cinema**

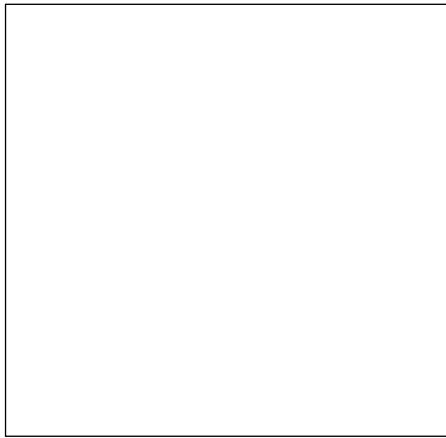

1 Jig set

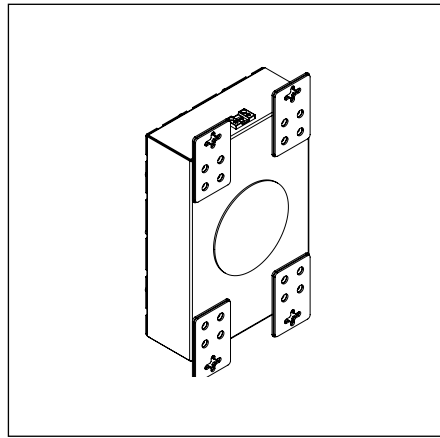

2

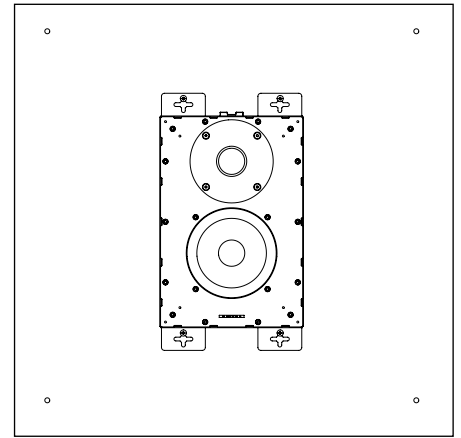

3

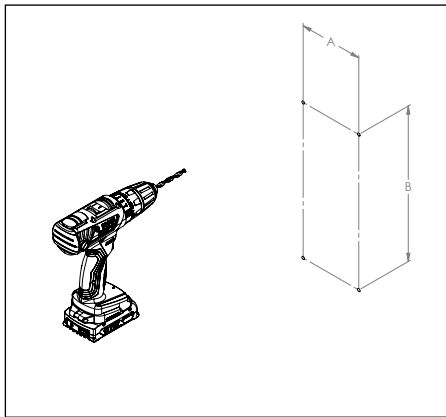

4

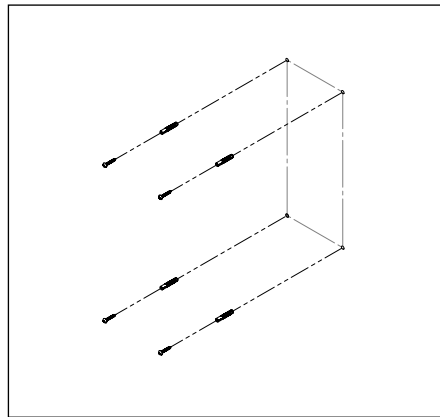

5

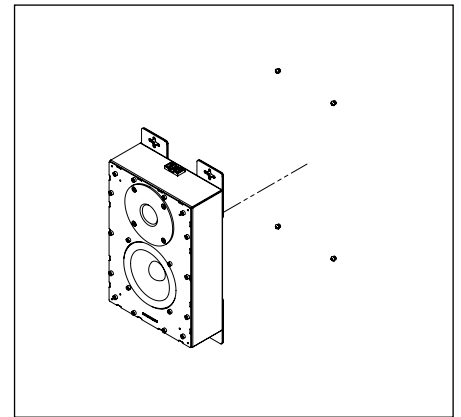

6

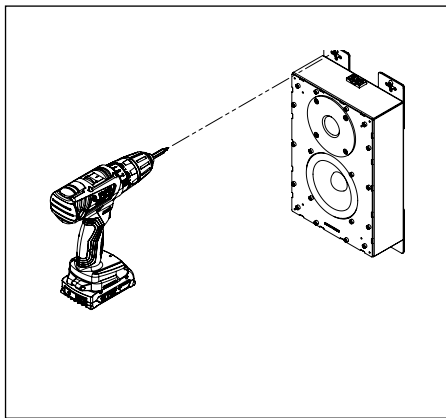

7

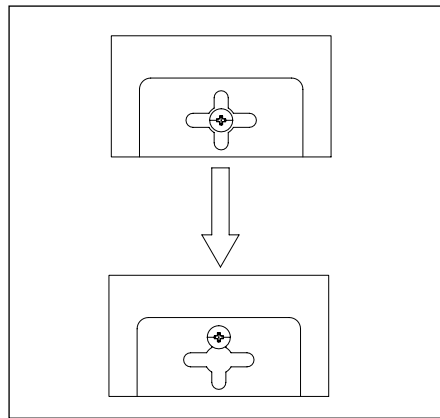

8

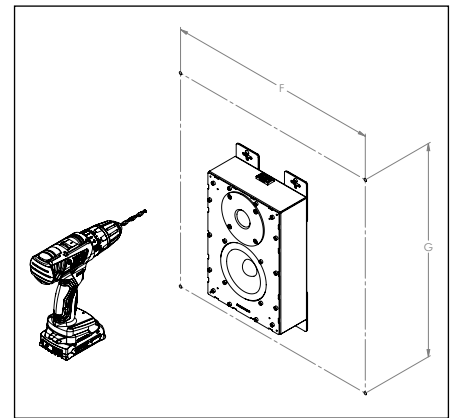

9

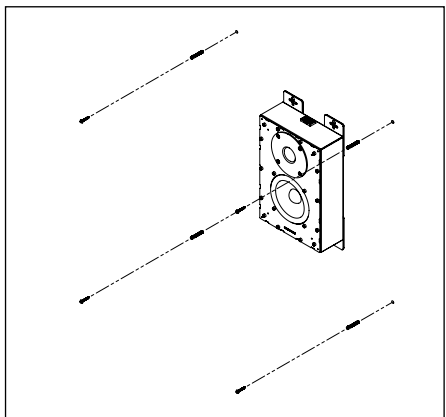

10

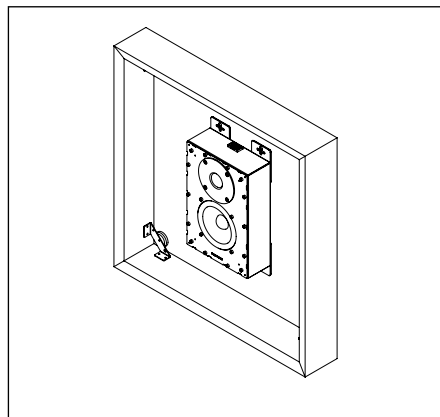

11