



TYPHON-AXF8
TYPHON-AXF8-BT
TYPHON-AXF12
TYPHON-AXF12-BT
TYPHON-AXF15
TYPHON-AXF15-BT

POWERFUL | PORTABLE | VERSATILE PA

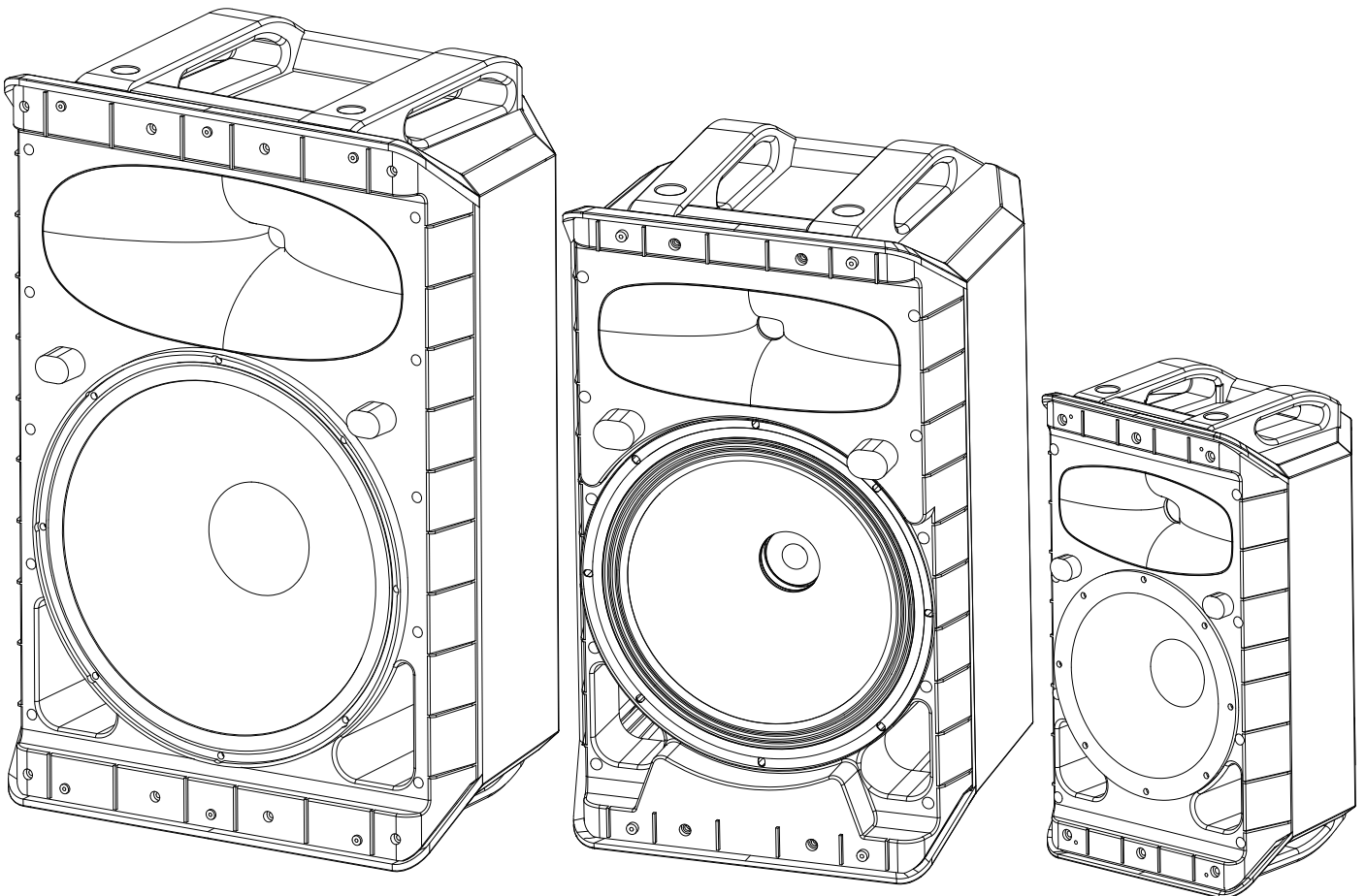
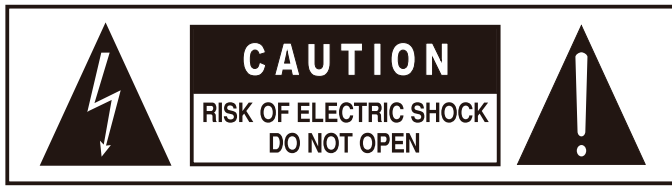

TABLE OF CONTENTS

IMPORTANT SAFETY INSTRUCTIONS	1
TYPHON - Pronounced - "TYF—ON"	2
IMPORTANT WARNINGS & SAFETY INSTRUCTIONS	3 - 4
REAR PANEL FEATURES	5 - 8
TECHNICAL DRAWINGS	9 - 10
SPECIFICATIONS	11 - 12

IMPORTANT SAFETY INSTRUCTIONS



CAUTION: To reduce the risk of electric shock, do not remove the top cover (or the rear section). No user serviceable parts inside; refer servicing to qualified personnel.

WARNING: To reduce the risk of fire or electric shock, do not expose this appliance to rain and moisture.



This symbol, wherever it appears, alerts you to the presence of uninsulated dangerous voltage inside the enclosure-voltage that may be sufficient to constitute a risk of shock.



This symbol, wherever it appears, alerts you to important operating and maintenance instructions in the accompanying literature. Please read the manual.

2. DETAILED SAFETY INSTRUCTIONS:

- (1) Read these instructions.
- (2) Keep these instructions.
- (3) Heed all warnings.
- (4) Follow all instructions.
- (5) Do not use this device near water.
- (6) Clean only with a dry cloth.
- (7) Do not block any ventilation openings. Install in accordance with the manufacturer s instructions.
- (8) Do not install near any heat sources such as radiators, heat registers, stoves, or other apparatus (including amplifiers) that produce heat.
- (9) Do not defeat the safety purpose of the polarized or grounding-type plug. A polarized plug has two blades with one wider than the other. A grounding type plug has two blades and a third grounding prong. The wide blade or the third prong are provided for your safety. If the provided plug does not fit into your outlet, consult an electrician for replacement of the obsolete outlet.

TYPHON - Pronounced - "TYF—ON"

In ancient mythology, Typhon was a giant who brought fear to his enemies. From a similar era to the Titans, it is said that the God Typhon had the power to create and control massive wind tornadoes in his battles. Mythology also often refers to him as being invincible.

Power, control and "invincibility" are all features which Typhon active loudspeakers have been designed around.

8", 12" and 15" choices and all are available as an aptX Bluetooth model.

A polypropylene cabinet design with a full frontal steel grille houses the most advanced active point source loudspeakers ever created by Wharfedale Pro. This injection moulded cabinet is carefully engineered to feature 5 carry handles making transportation easy and well balanced.

Advanced internal DSP algorithms including FIR filters generate a sound stage which surpasses the dimensions of the cabinet. The two separate Class D power amps in each Typhon loudspeaker deliver huge output power while keeping the overall weight to minimum.

The efficiency of the amplifier stage means that Typhon uses convection cooling - resulting in a more reliable product with quieter operation.

Custom Wharfedale Pro transducers have been selected for Typhon. The custom compression driver features a 1.75" voice coil. This is coupled to a 100° x 80° waveguide for smooth HF dispersion. The custom Wharfedale Pro low frequency transducers have newly designed ferrite cores and use flat coil windings to aid cooling.

All models feature a moisture rejecting cone material which allows Typhon to be used in damp or humid conditions.

The Typhon-AXF15-BT, Typhon-AXF12-BT and Typhon-AXF8-BT feature aptX Bluetooth input connectivity and stereo linking which makes setup with mobile devices simple and cable free.

Features

Typhon-AXF8 Typhon-AXF8-BT

8" Bi-amplified active loudspeaker
1.75" HF compression driver
720 w Continuous
1440 w Peak
127 dB Max SPL @ 1 meter
2.5" LF voice coil

Typhon-AXF12 Typhon-AXF12-BT

12" Bi-amplified active loudspeaker
1.75" HF compression driver
720 w Continuous
1440 w Peak
129 dB Max SPL @ 1 meter
2.5" LF voice coil

Typhon-AXF15 Typhon-AXF15-BT

15" Bi-amplified active loudspeaker
1.75" HF compression driver
770 w Continuous
1540 w Peak
130 dB Max SPL @ 1 meter
3.0" LF voice coil

IMPORTANT WARNINGS & SAFETY INSTRUCTIONS

1. Read these instructions – All the safety and operating instructions should be read before this product is operated.
2. Keep these instructions – The safety and operating instructions should be retained for future reference.
3. Heed all warnings – All warnings on the appliance and in the operating instructions should be adhered to.
4. Follow all instructions – All operating and use instructions should be followed.
5. Do not use this apparatus near water – The appliance should not be used near water or moisture – for example, in a wet basement or near a swimming pool, and the like.
6. Clean only with dry cloth.
7. Do not block any ventilation openings. Install in accordance with the manufacture's instructions.
8. Do not install near any heat sources such as radiators, heat registers, stoves, or other apparatus (including amplifiers) that produce heat.
9. Do not defeat the safety purpose of the polarized or grounding plug. A polarized plug has two blades with one wider than the other. A grounding plug has two blades and a third grounding prong. The wide blade or the third prong is provided for your safety. If the provided plug does not fit into your outlet, consult an electrician for replacement of the obsolete outlet.
10. Protect the power cord from being walked on or pinched particularly at the plugs, convenience receptacles, and at the point where they exit from the apparatus.
11. Only use attachments/accessories specified by the manufacturer.
12. Use only with the cart, stand, tripod, bracket, or table specified by the manufacturer, or sold with the apparatus. When a cart or rack is used, use caution when moving the cart/apparatus combination to avoid injury from tip-over.



13. Unplug the apparatus during lightning storms or when unused for long periods of time.
14. Refer all servicing to qualified personnel. Servicing is required when the apparatus has been damaged in any way, such as power supply cord or plug is damaged, liquid has been spilled or objects have fallen into the apparatus has been exposed to rain or moisture, does not operate normally, or has been dropped.
15. CAUTION: These servicing instructions are for use by qualified service personnel only. To reduce the risk of electric shock, do not perform any servicing other than that contained in the operating instructions unless you are qualified to do so.
16. WARNING: To reduce the risk of fire or electric shock, do not expose this apparatus to rain or moisture. The apparatus shall not be exposed to dripping or splashing and that objects filled with liquids, such as vases, shall not be placed on apparatus.



17. This lightning flash with arrowhead symbol within an equilateral triangle is intended to alert the user to the presence of non-insulated "dangerous voltage" within the product's enclosure that may be of sufficient magnitude to constitute a risk of electric shock.
 - Warning: To reduce the risk of electric shock, do not remove cover (or back) as there are no user-serviceable parts inside. Refer servicing to qualified personnel.
 - The exclamation point within an equilateral triangle is intended to alert the user to the presence of important operating and maintenance instructions in the literature accompanying the appliance.
18. ⚡ Protective earthing terminal. The apparatus should be connected to a mains socket outlet with a protective earthing connection.
19. the ventilation should not be impeded by covering the ventilation openings with items, such as newspapers, table-cloths, curtains, etc.;
20. No naked flame sources, such as lighted candles, should be placed on the apparatus.
21. Attention should be drawn to environmental aspects of battery disposal.
22. The mains plug is used as disconnect device, the disconnect device shall remain readily operable.
23. The product is designed to use in moderate climates.

REAR PANEL FEATURES

Typhon-AXF15 and Typhon-AXF15-BT

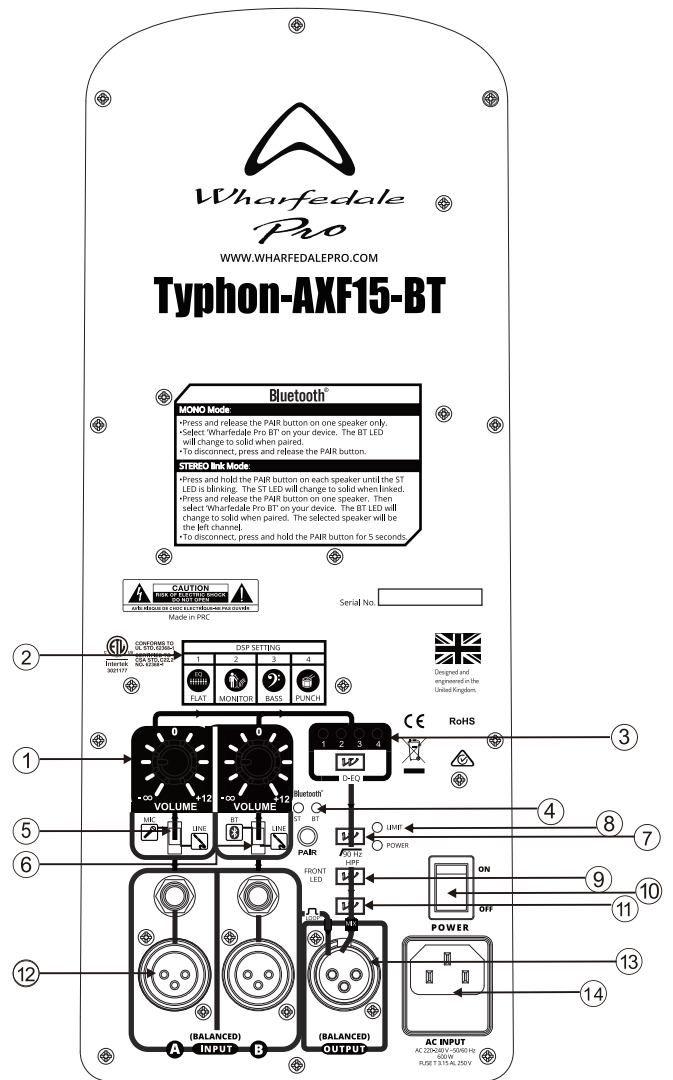
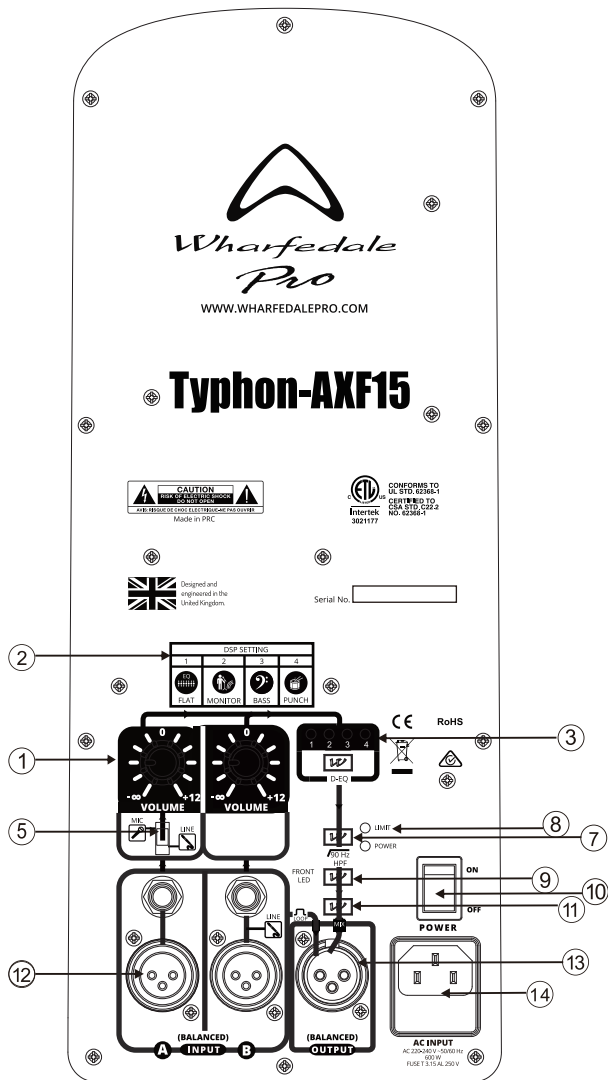

Typhon-AXF12 and Typhon-AXF12-BT

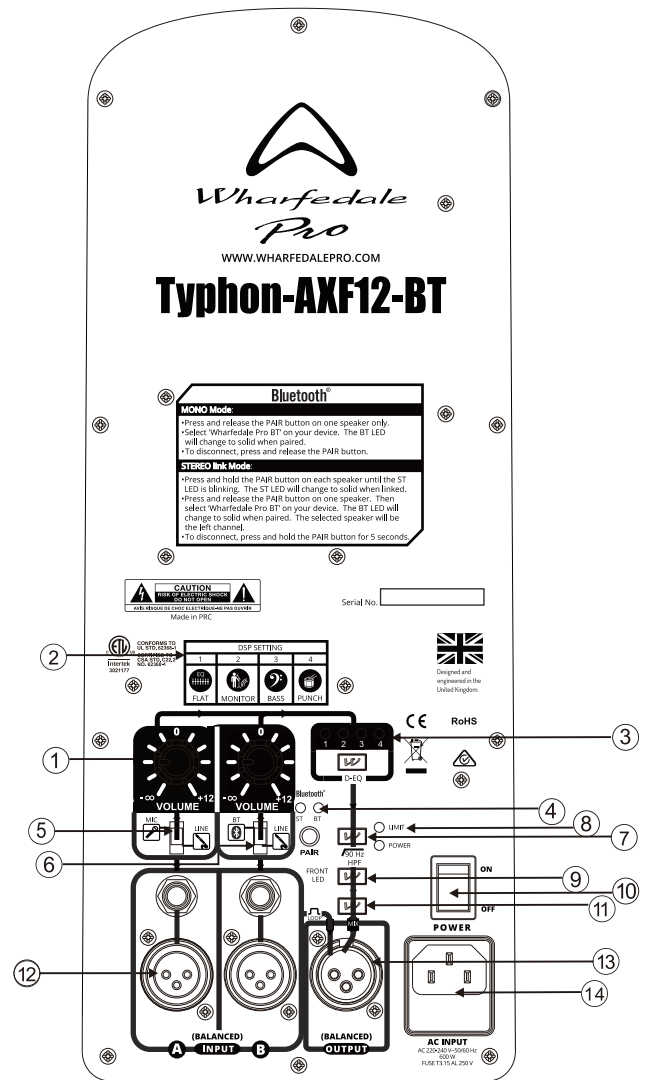
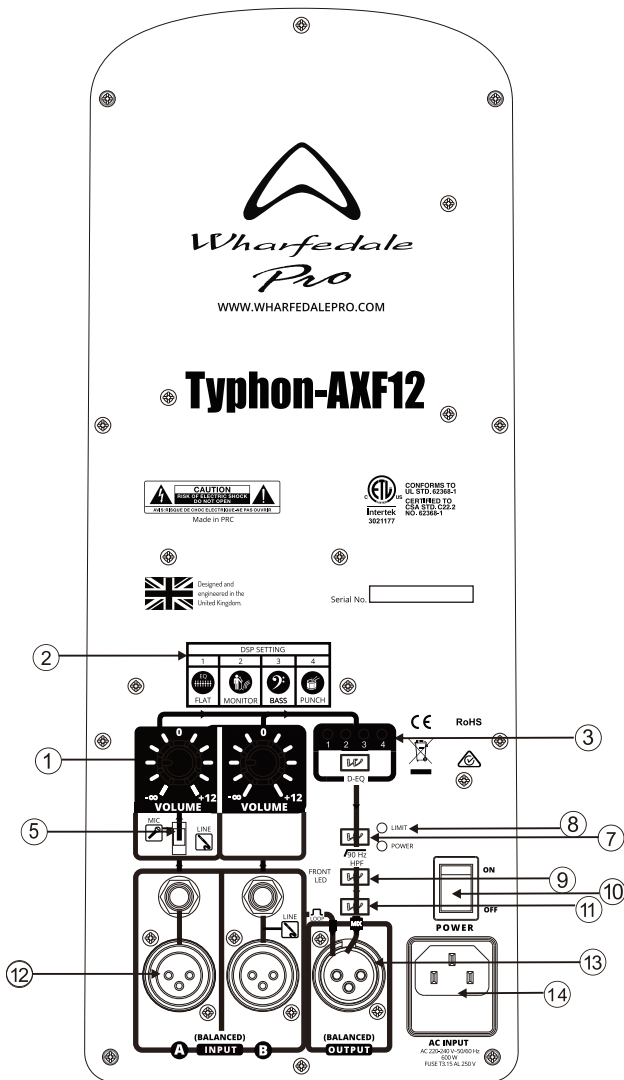

Typhon-AXF8 and Typhon-AXF8-BT

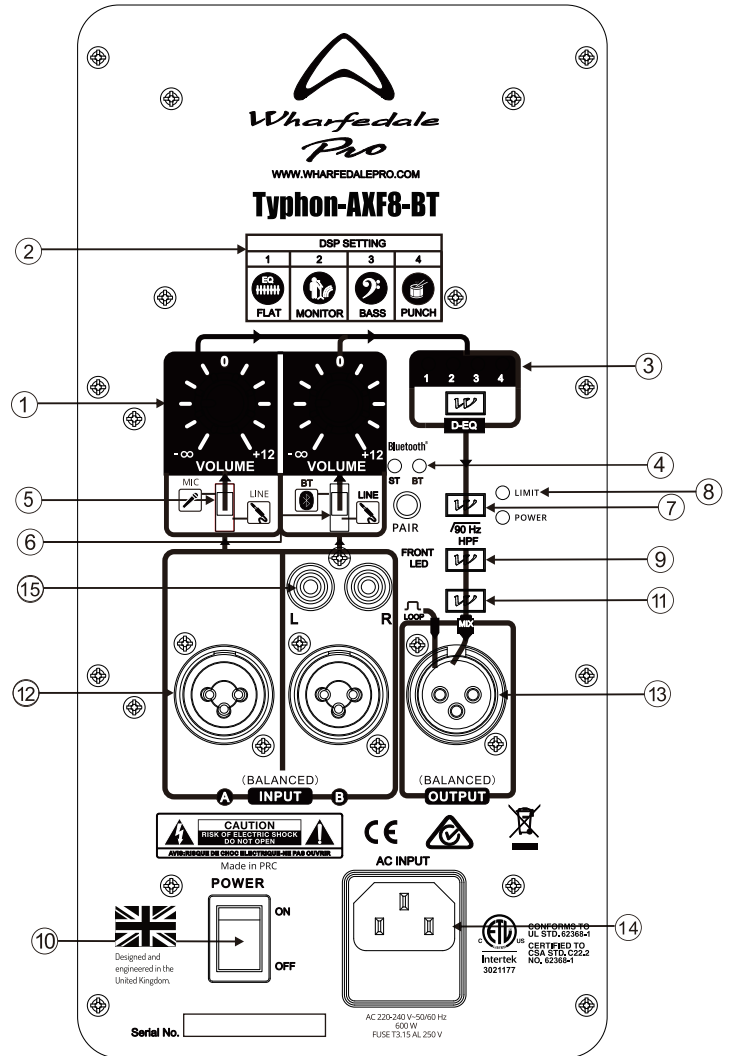
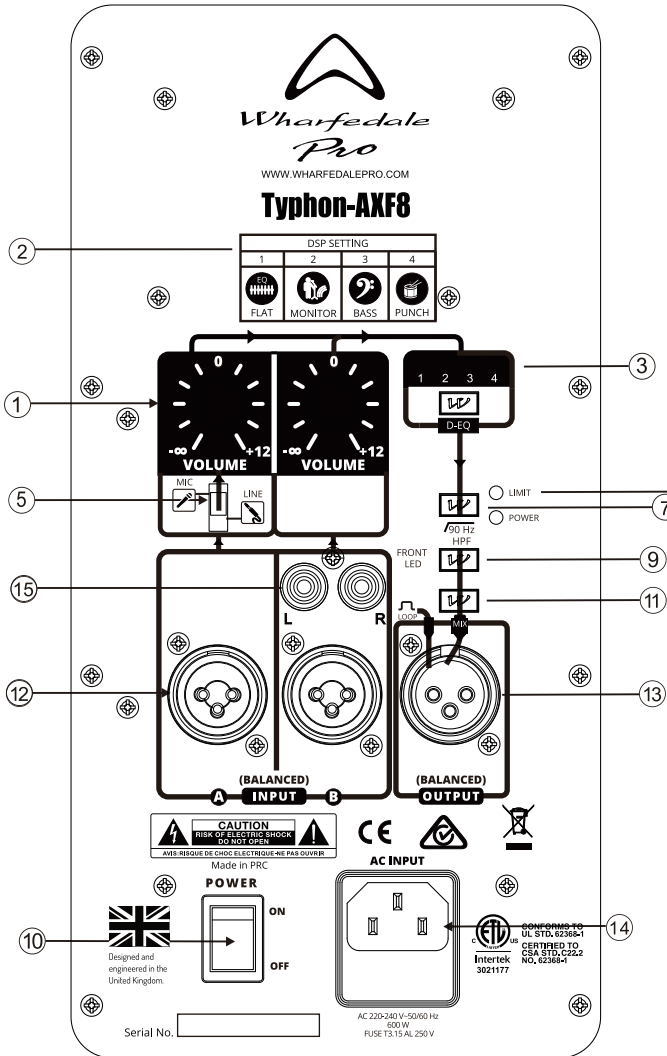

1. **VOLUME controls for INPUT A and INPUT B:** These knobs control the level of each input channel.
2. **DSP setting :** (4 modes) 1) FLAT 2) MONITOR 3) BASS 4) PUNCH
3. **DSP Selection:** With each tap of the D-EQ button, the DSP will step through each of the 4 above DSP modes. The LED will show which DSP mode is currently active.
4. **Bluetooth operation (Typhon-AXF15-BT, Typhon-AXF12-BT and Typhon-AXF8-BT only) :**

a. MONO Mode: Press and release the PAIR button on one speaker only. Select "Typhon-AXF15-BT" OR "Typhon-AXF12-BT" OR "Typhon-AXF8-BT" on your device. The BT LED will change to solid when paired. To disconnect, press and release the PAIR button.

b. STEREO Link Mode: For use with 2 units of Typhon-AXF15-BT OR Typhon-AXF12-BT OR Typhon-AXF8-BT, Press and hold the PAIR button on each speaker until the ST LED is blinking. The ST LED will change to solid when Linked. Press and release the PAIR button on one speaker. Then select "Typhon-AXF15-BT" OR "Typhon-AXF12-BT" OR "Typhon-AXF8-BT" on your device. The BT LED will change to solid when paired. The selected speaker will be the left channel. To disconnect, press and hold the PAIR button for 5 Seconds.

Transmission distance note : A single speaker working range is about 15 meters (Bluetooth device (eg Phone) to single speaker). When using a Bluetooth Typhon in stereo link mode the working range is about 10m (Bluetooth device (eg Phone) to speaker). In this mode the linked speakers can be up to 8m apart.

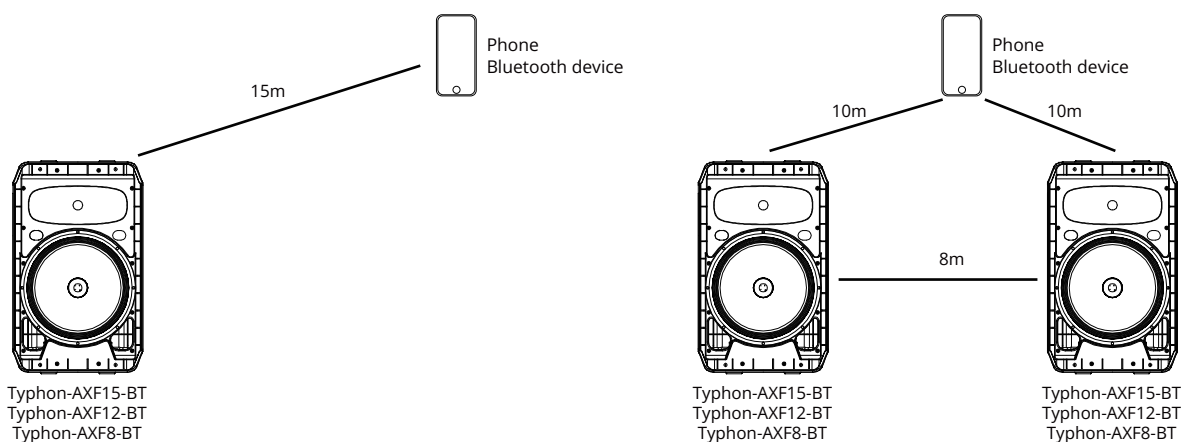

5. **GAIN selection switch A:** This switch selects the proper gain structure for INPUT A. If a microphone is connected to INPUT A, use mic mode (up). If the signal source is anything other than a microphone (eg an analogue playback device, keyboard or mixer output) use the line selection (down).
6. **GAIN selection switch B:** This switch selects the proper gain structure for INPUT B. If a Bluetooth device is connected to INPUT B, use BT mode (up). If the signal source is anything other than a Bluetooth device (eg analogue playback device, keyboard or mixer output) use the line selection (down).
7. **90Hz Hi Pass Filter switch:** Used to reduce bass buildup due to half space loading. This is especially useful when using the Typhon on the floor as a floor monitor. 8. **Power "ON" indicator LED and LIMIT indicator LED:** The bracketed LED to the left of the POWER switch illuminates when the power switch is in the 'ON' position. The LIMIT LED illuminates when the signal limiter is limiting the level of the signal. This process prevents distortion and overload.
9. **Horn LED defeat switch:** Switches off the front horn power LED for discrete applications.
10. **POWER ON / OFF switch:** This switch turns the power on and off.
11. **Output source "LOOP / MIX" switch:** In the "LOOP" mode, this switch routes the signal of INPUT B to the line level XLR OUTPUT jack, bypassing the EQ section and volume control. When in the MIX mode, this switch routes the combined (or "mixed") signals of both INPUT A and INPUT B to the line level XLR OUTPUT jack.
12. **XLR and ¼" input jacks for INPUT A and INPUT B.:** These connectors allow XLR or ¼" balanced input connections to INPUT A and INPUT B.
13. **XLR line level OUTPUT:** This connector provides a balanced line level output for connection to additional active loudspeakers (such as another Typhon-AXF15), powered subwoofers or external amplifiers.
14. **POWER cord input:** Typhon uses a standard IEC, three prong, grounded AC electrical connection. Be sure that you are plugging into the correct source voltage that matches what is indicated just below the power cord jack.
15. **RCA Inputs:** Typhon-AXF8 and Typhon-AXF8-BT only. For connection to stereo line level audio sources.

TECHNICAL DRAWINGS

Typhon-AXF15 and Typhon-AXF15-BT

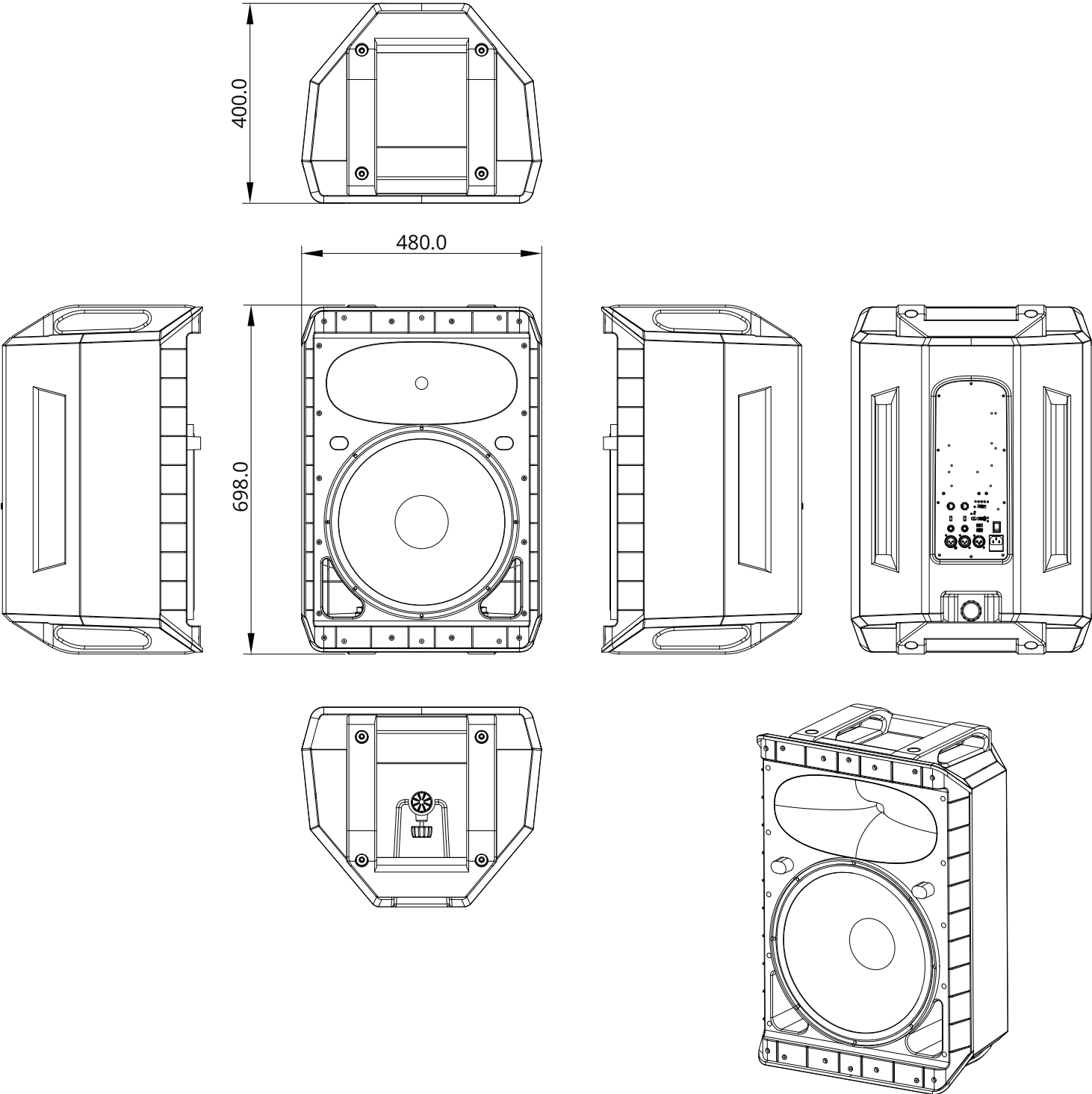

TECHNICAL DRAWINGS

Typhon-AXF12 and Typhon-AXF12-BT

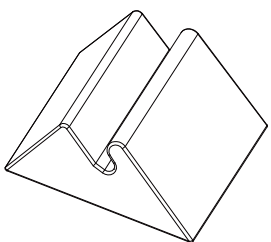
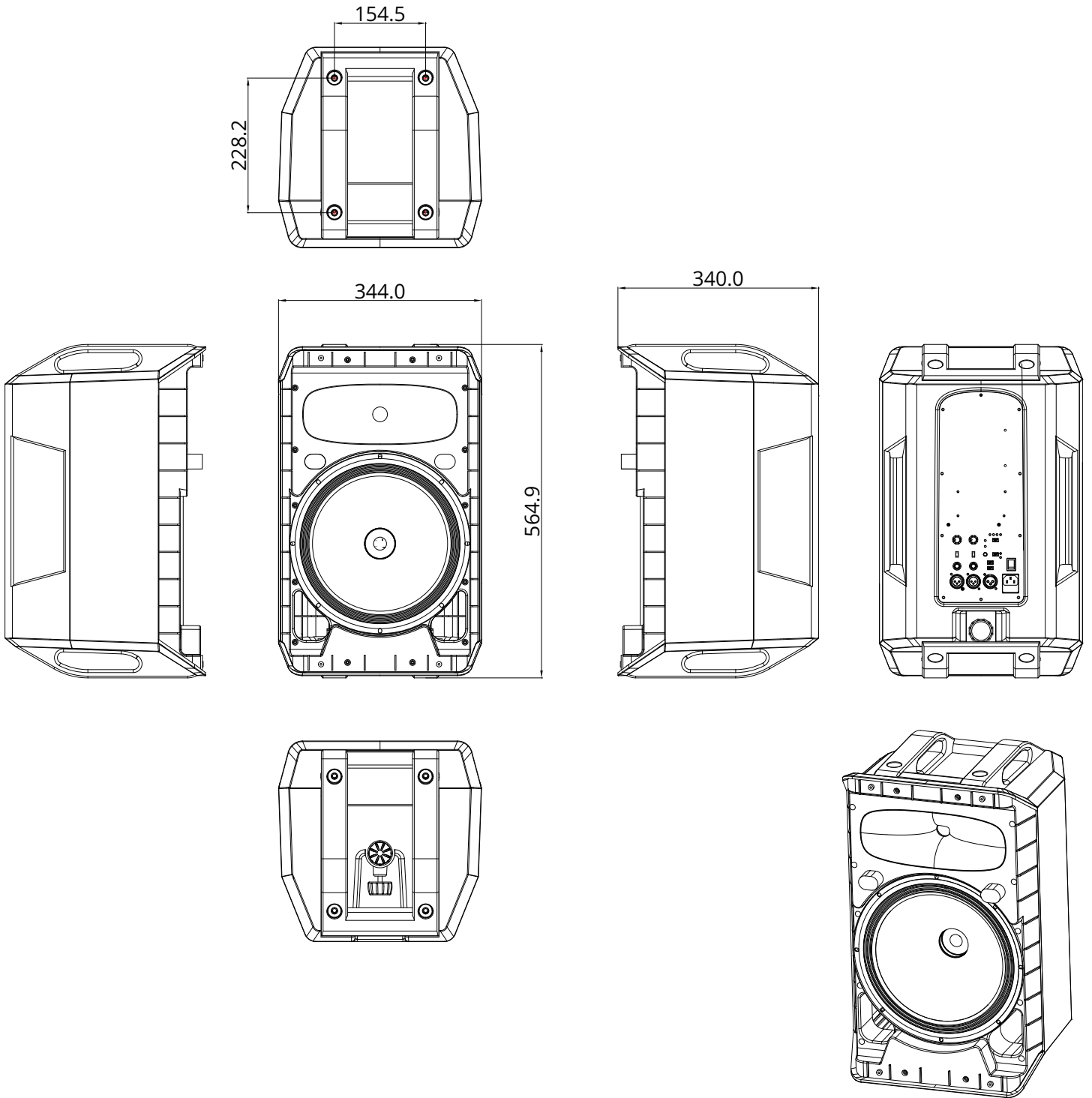

Typhon 12" Monitor Wedge

Typhon 12" models is supplied with a monitor wedge adaptor. This supplied accessory gives you the perfect angle when using Typhon as a stage monitor.

TECHNICAL DRAWINGS

Typhon-AXF8 and Typhon-AXF8-BT

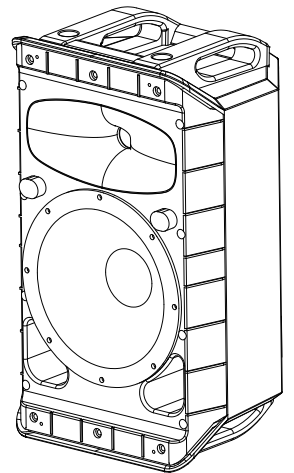
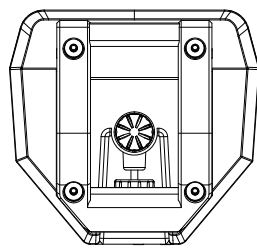
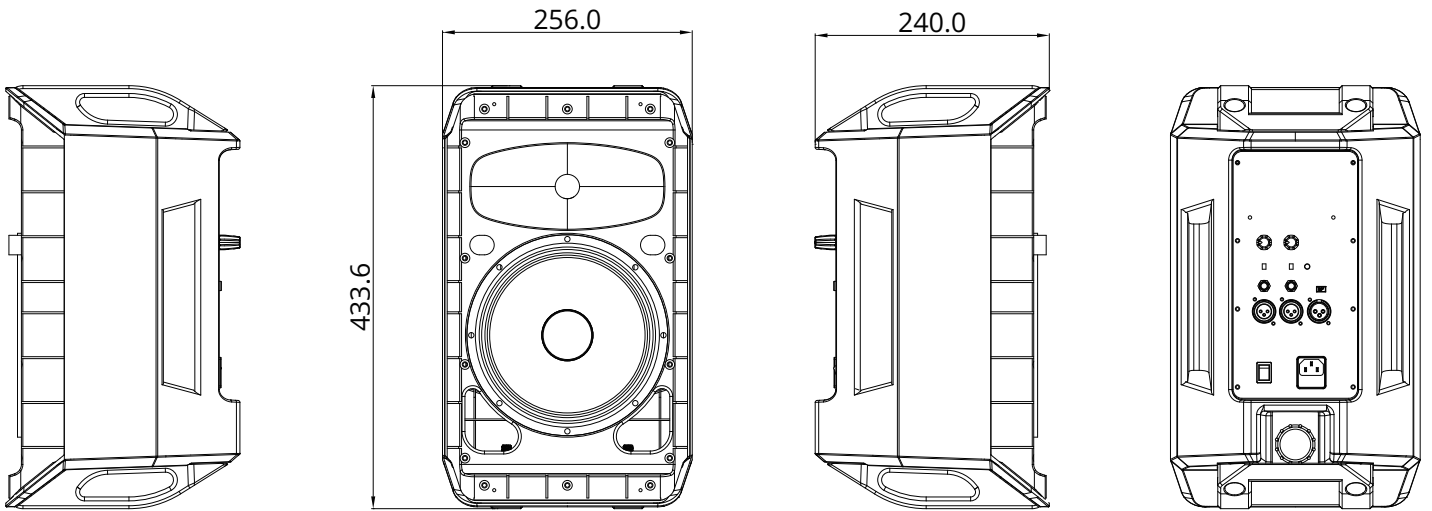
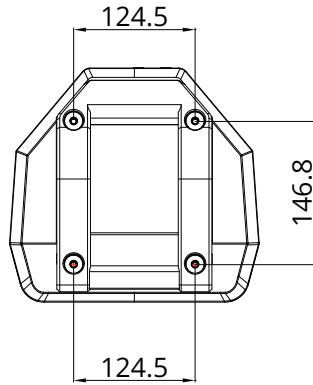

SPECIFICATIONS

Model Name	Typhon-AXF15	Typhon-AXF15-BT
System Type	Active 15" 2-way	Active 15" 2-way
Frequency Response (+/-3dB)	45 Hz-20 KHz	45 Hz-20 KHz
Frequency Range (- 10 dB)	40 Hz-20 KHz	40 Hz-20 KHz
Maximum SPL (peak @1m)	130 dB	130 dB
Sensitivity (@ 1W / 1m)	99 dB	99 dB
Low Frequency Transducer		
Size (mm / inches)	381 mm / 15"	381 mm / 15"
Voice-Coil Size (mm / inches)	75 mm / 3.0"	75 mm / 3.0"
Rated Impedance	4 Ω	4 Ω
High Frequency Transducer		
HF Driver Type	Compression Driver	Compression Driver
Coil Size (mm / inches)	44 mm / 1.75"	44 mm / 1.75"
Exit Size (mm / inches)	25mm / 1"	25mm / 1"
Diaphragm Material	Titanium	Titanium
Rated Impedance	8 Ω	8 Ω
Nominal Coverage (H x V)	Hybrid Symmetry Horn 100° x 80°	Hybrid Symmetry Horn 100° x 80°
Amplifiers		
Amplifiers	2 x Class D	2 x Class D
Power Rating:	1540 W Peak (1300 W LF + 240 W HF), 770 W Continuous (650 W LF + 120 W HF)	1540 W Peak (1300 W LF + 240 W HF), 770 W Continuous (650 W LF + 120 W HF)
DSP Controls---D-EQ	FLAT/MONITOR/BASS/PUNCH	FLAT/MONITOR/BASS/PUNCH
Amplifier Protection		
Power On Protection	Yes	Yes
Thermal Protection	Yes	Yes
Low Line Voltage Shut Down	Yes	Yes
Driver Protection	Yes	Yes
DC Protection	Yes	Yes
Short Protection	Yes	Yes
Clip Limiter	Yes	Yes
Limiter Indicator	Yes	Yes
Power Indicator	Yes	Yes
Inputs		
Input A - type	Balanced	Balanced/Bluetooth(aptX,with link Stereo)
Input Sensitivity	775mV (0dBu)	775mV (0dBu)
Maximum Input Level	4V	4V
Input Connectors	2 x XLR, 2 x 6.3 mm jack (Line/MIC)	2 x XLR, 2 x 6.3 mm jack (Line/MIC)
Input Impedance	20K ohms	20K ohms
Line Output		
Line Output Connector	XLR	XLR
Loop Gain	0 dB	0 dB
AC Power details		
Power Supply	220~240VAC / 100~120VAC 50/60Hz	220~240VAC / 100~120VAC 50/60Hz
Rigging / Bracket / Mounting Options	9 x M8 threaded inserts Pole-mount receptacle with lock screw Optional WPB-2 wall-mount bracket	9 x M8 threaded inserts Pole-mount receptacle with lock screw Optional WPB-2 wall-mount bracket
Handles	2 carry handles (on top and bottom side)	2 carry handles (on top and bottom side)
Enclosure		
Enclosure Material and finish	Injection Moulded Polypropylene	Injection Moulded Polypropylene
Colour Options	Black paint	Black paint
Grille Material & Finish	steel	steel
Dimensions - Unpacked (mm / inches):		
Height	697.7 mm / 27.5"	697.7 mm / 27.5"
Width Front	480 mm / 18.9"	480 mm / 18.9"
Width Rear	186.2 mm / 7.3"	186.2 mm / 7.3"
Depth	400 mm / 15.7"	400 mm / 15.7"
Dimensions - Packed (mm / inches):		
Height	788 mm / 31.02"	788 mm / 31.02"
Width Front	550 mm / 21.9"	550 mm / 21.9"
Width Rear	550 mm / 21.9"	550 mm / 21.9"
Depth	475 mm / 18.7"	475 mm / 18.7"
Net Weight (kg / lbs)	27.3 kg / 60.06 lbs	27.3 kg / 60.06 lbs
Gross Weight (kg / lbs)	30.0 kg / 66 lbs	30.0 kg / 66 lbs

Model Name	Typhon-AXF12	Typhon-AXF12-BT
System Type	Active 12" 2-way	Active 12" 2-way
Frequency Response (+/-3dB)	55 Hz-20 kHz	55Hz-20 kHz
Frequency Range (- 10 dB)	50 Hz-20 kHz	50Hz-20 kHz
Maximum SPL (peak @1m)	129 dB	129 dB
Sensitivity (@ 1W / 1m)	98 dB	98 dB
Low Frequency Transducer		
Size (mm / inches)	305 mm / 12"	305 mm / 12"
Voice-Coil Size (mm / inches)	65 mm / 2.5"	65 mm / 2.5"
Rated Impedance	4 Ω	4 Ω
High Frequency Transducer		
HF Driver Type	Compression Driver	Compression Driver
Coil Size (mm / inches)	44 mm / 1.75"	44 mm / 1.75"
Exit Size (mm / inches)	25 mm / 1"	25 mm / 1"
Diaphragm Material	Titanium	Titanium
Rated Impedance	8 Ω	8 Ω
Nominal Coverage (H x V)	Hybrid Symmetry Horn 100° x 80°	Hybrid Symmetry Horn 100° x 80°
Amplifiers		
Amplifiers	2 x Class D	2 x Class D
Power Rating:	1440 W Peak (1200 W LF + 240 W HF), 720 W Continuous (600 W LF + 120 W HF)	1440 W Peak (1200 W LF + 240 W HF), 720 W Continuous (600 W LF + 120 W HF)
DSP Controls---D-EQ	FLAT/MONITOR/BASS/PUNCH	FLAT/MONITOR/BASS/PUNCH
Amplifier Protection		
Power On Protection	Yes	Yes
Thermal Protection	Yes	Yes
Low Line Voltage Shut Down	Yes	Yes
Driver Protection	Yes	Yes
DC Protection	Yes	Yes
Short Protection	Yes	Yes
Clip Limiter	Yes	Yes
Limiter Indicator	Yes	Yes
Power Indicator	Yes	Yes
Inputs		
Input A - type	Balanced	Balanced/Bluetooth(aptX,with link Stereo)
Input Sensitivity	775 mV (0 dBu)	775 mV (0 dBu)
Maximum Input Level	4 V	4 V
Input Connectors	2 x XLR, 2 x 6.3 mm (Line/MIC)	2 x XLR, 2 x 6.3 mm (Line/MIC)
Input Impedance	20K ohms	20K ohms
Line Output		
Line Output Connector	XLR	XLR
Loop Gain	0 dB	0 dB
AC Power details		
Power Supply	220~240VAC / 100~120VAC 50/60Hz	220~240VAC / 100~120VAC 50/60Hz
Rigging / Bracket / Mounting Options	9 x M8 threaded inserts Pole-mount receptacle with lock screw Optional WPB-2 wall-mount bracket	9 x M8 threaded inserts Pole-mount receptacle with lock screw Optional WPB-2 wall-mount bracket
Handles	4 carry handles (on top and bottom side)	4 carry handles (on top and bottom side)
Enclosure		
Enclosure Material and finish	Injection Moulded Polypropylene	Injection Moulded Polypropylene
Colour Options	Black paint	Black paint
Grille Material & Finish	steel	steel
Dimensions - Unpacked (mm / inches):		
Height	558 mm / 22.0"	558 mm / 22.0"
Width Front	344 mm / 13.6"	344 mm / 13.6"
Width Rear	245 mm / 9.6"	245 mm / 9.6"
Depth	340 mm / 13.4"	340 mm / 13.4"
Dimensions - Packed (mm / inches):		
Height	645 mm / 25.4"	645 mm / 25.4"
Width Front	425 mm / 16.7"	425 mm / 16.7"
Width Rear	425 mm / 16.7"	425 mm / 16.7"
Depth	419 mm / 16.5"	419 mm / 16.5"
Net Weight (kg / lbs)	16.2 kg / 35.6 lbs	16.2 kg / 35.6 lbs
Gross Weight (kg / lbs)	18.9 kg / 41.6 lbs	18.9 kg / 41.6 lbs

Model Name	Typhon-AXF8	Typhon-AXF8-BT
System Type	Active 8" 2-way	Active 8" 2-way
Frequency Response (+/-3dB)	65 Hz-20 kHz	65 Hz-20 kHz
Frequency Range (- 10 dB)	60 Hz-20 kHz	60 Hz-20 kHz
Maximum SPL (peak @1m)	127 dB	127 dB
Sensitivity (@ 1W / 1m)	96 dB	96 dB
Low Frequency Transducer		
Size (mm / inches)	203.8 mm / 8"	203.8 mm / 8"
Voice-Coil Size (mm / inches)	65 mm / 2.5"	65 mm / 2.5"
Rated Impedance	4 Ω	4 Ω
High Frequency Transducer		
HF Driver Type	Compression Driver	Compression Driver
Coil Size (mm / inches)	44 mm / 1.75"	44 mm / 1.75"
Exit Size (mm / inches)	25 mm / 1"	25 mm / 1"
Diaphragm Material	Titanium	Titanium
Rated Impedance	8 Ω	8 Ω
Nominal Coverage (H x V)	Hybrid Symmetry Horn 100° x 80°	Hybrid Symmetry Horn 100° x 80°
Amplifiers		
Amplifiers	2 x Class D	2 x Class D
Power Rating:	1440 W Peak (1200 W LF + 240 W HF), 720 W Continuous (600 W LF + 120 W HF)	1440 W Peak (1200 W LF + 240 W HF), 720 W Continuous (600 W LF + 120 W HF)
DSP Controls---D-EQ	FLAT/MONITOR/BASS/PUNCH	FLAT/MONITOR/BASS/PUNCH
Amplifier Protection		
Power On Protection	Yes	Yes
Thermal Protection	Yes	Yes
Low Line Voltage Shut Down	Yes	Yes
Driver Protection	Yes	Yes
DC Protection	Yes	Yes
Short Protection	Yes	Yes
Clip Limiter	Yes	Yes
Limiter Indicator	Yes	Yes
Power Indicator	Yes	Yes
Inputs		
Input A – type	Balance / RCA	Balanced/RCA/Bluetooth(aptX,with link Stereo)
Input Sensitivity	775 mV (0dBu)	775 mV (0dBu)
Maximum Input Level	4 V	4 V
Input Connectors	2 x XLR, 2 x 6.3mm, 2 x RCA (Line/MIC)	2 x XLR, 2 x 6.3mm, 2 x RCA (Line/MIC)
Input Impedance	20K ohms	20K ohms
Line Output		
Line Output Connector	XLR	XLR
Loop Gain	0 dB	0 dB
AC Power details		
Power Supply	220~240VAC / 100~120VAC 50/60Hz	220~240VAC / 100~120VAC 50/60Hz
Rigging / Bracket / Mounting Options	8xM6 (1XM8 Back) threaded inserts Pole-mount receptacle with lock screw Optional WPB-2 wall-mount bracket	8xM6 (1XM8 Back) threaded inserts Pole-mount receptacle with lock screw Optional WPB-2 wall-mount bracket
Handles	4 carry handles (on top and bottom side)	4 carry handles (on top and bottom side)
Enclosure		
Enclosure Material and finish	Injection Moulded Polypropylene	Injection Moulded Polypropylene
Colour Options	Black paint	Black paint
Grille Material & Finish	steel	steel
Dimensions - Unpacked (mm / inches):		
Height	433.6 mm / 17.1"	433.6 mm / 17.1"
Width Front	256 mm / 10.1"	256 mm / 10.1"
Width Rear	100.1 mm / 3.9"	100.1 mm / 3.9"
Depth	240 mm / 9.5"	240 mm / 9.5"
Dimensions - Packed (mm / inches):		
Height	509 mm / 20.0"	509 mm / 20.0"
Width Front	326 mm / 12.8"	326 mm / 12.8"
Width Rear	326 mm / 12.8"	326 mm / 12.8"
Depth	310 mm / 12.2"	310 mm / 12.2"
Net Weight (kg / lbs)	10.7 kg / 23.5 lbs	10.7 kg / 23.5 lbs
Gross Weight (kg / lbs)	12.7 kg / 27.9 lbs	12.7 kg / 27.9 lbs

WHARFEDALE PRO LIMITED WARRANTY

Wharfedale Pro products are warranted of manufacturing or material defects for a period of one year from the original date of purchase. In the event of malfunction, contact your authorized Wharfedale Pro dealer or distributor for information.

*Be aware that warranty details may differ from country to country. Contact your dealer or distributor for information. These terms do not infringe your statutory rights.



*Wharfedale
Pro*

www.wharfedalepro.com

IAG House, 13/14 Glebe Road, Huntingdon, Cambridgeshire, PE29 7DL, UK
www.wharfedalepro.com

Wharfedale Pro reserves the right to alter or improve specifications without notice.
All rights reserved © 2025 Wharfedale Pro. Wharfedale Pro is a member of the IAG Group.